



CLEVELAND VIBRATOR COMPANY

& **HK** Technologies, Inc. An Affiliate of The Cleveland Vibrator Company



FABRICATED EQUIPMENT

SCREENERS



Jamieson Equipment Company
www.jamiesonequipment.com
toll free 800.875.0280

PRODUCT OVERVIEW

SCREENERS & SEPARATORS

The Cleveland Vibrator Company offers a wide range of light, medium and heavy-duty vibratory screeners for sorting and separating materials.

Screening equipment can increase and optimize your production capabilities with:

- 24 x 7 continuous duty
- Vibration designed and tuned for maximum material throughput
- 100% screen surface usage
- High quality construction, warranty and service



The Cleveland Vibrator Company tailors our product to the individual needs of your business. Call today to find out how we can improve your productivity and profits.



HyBrute™ Screener • Pg. 8 ▶

APPLICATIONS

The Cleveland Vibrator Company vibratory screeners are used to separate materials by particle size, remove small amounts of oversize or fine material, or remove excess liquid from finished products.

Our selection includes pneumatic, electromagnetic and electromagnetically powered units available with single, double or triple decks for materials between 20 microns and 4 inches.

TESTING

The Cleveland Vibrator Company operates and maintains a testing lab where samples of customer material may be received and tested. This testing ensures that the proper equipment is supplied for the unique applications of your business.

IDEAL FOR...

- Plastics
- Scrap & Recycling
- Mining
- Raw Materials
- Fine Powders
- Chemicals
- Pharmaceuticals
- Powdered Metals
- Super Abrasives
- Food

AIR POWERED SCREENERS

Air powered screeners utilize a reciprocating air cushioned piston, and consist of a quick acting valve, air line filter, pressure regulator gauge, lubricator, and a 5' air hose with pipe fittings.

Have dimensions certified for installation purposes.

LIGHT DUTY

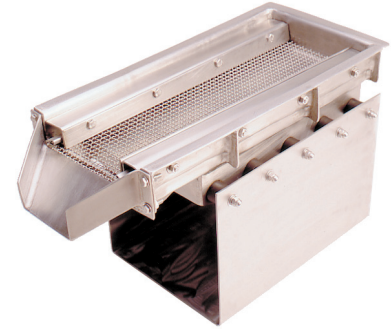
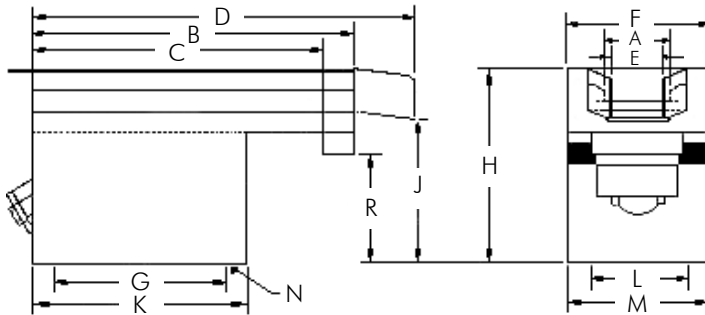

Model SF-A - 624-125 ▲

SF-A • LIGHT DUTY AIR POWERED SCREENERS

MODEL NUMBER	A TROUGH WIDTH	B TROUGH LENGTH	C	D	E	F	G	H	J	K	L	M	N	R
SF-A - 316-100	3"	16"	14"	18"	2"	6 1/2"	8"	9 1/2"	7"	10"	4"	6 1/4"	5/16"	6 1/2"
SF-A - 420-125	4"	20"	17"	23"	3"	7 1/2"	10"	11 1/2"	8"	12"	4 1/2"	6 3/4"	7/16"	6 3/4"
SF-A - 624-200	6"	24"	21"	27"	4"	9 1/2"	14"	12 1/2"	9"	16"	5 1/2"	7 3/4"	7/16"	7 3/4"
SF-A - 830-300	8"	30"	26"	34"	5"	13"	16"	17"	13"	20"	11 3/4"	11 3/4"	7/16"	11"

MEDIUM & HEAVY DUTY

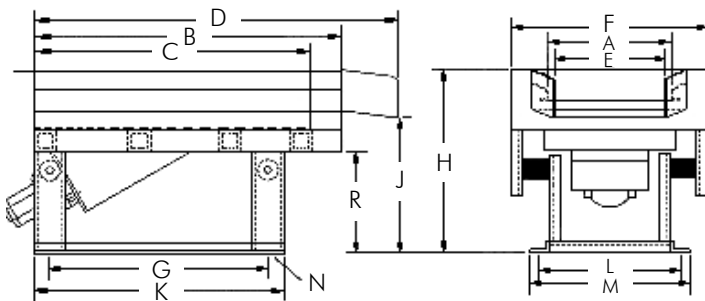

SF-A • MEDIUM & HEAVY-DUTY AIR POWERED SCREENERS

MODEL NUMBER	A TROUGH WIDTH	B TROUGH LENGTH	C	D	E	F	G	H	J	K	L	M	N	R
SF-A - 1236-350	12"	36"	32"	40"	8"	18 1/4"	24"	17"	13"	26"	18 1/4"	20 3/4"	9/16"	11"
SF-A - 1842-400	18"	42"	36"	48"	12"	25 1/4"	27"	24"	19"	32"	19 1/2"	21 1/2"	9/16"	15"
SF-A - 2448-500	24"	48"	42"	54"	16"	31 1/4"	33"	30"	25"	38"	25 1/2"	27 1/2"	9/16"	21"

EQUIPMENT FEATURES

ELECTROMECHANICAL SCREENER FEEDERS

STANDARD DESIGNS

The standard EMS includes:

- Impact plate at inlet area for product loading
- Below deck, twin dust-tight 1800 RPM drives
- Mild steel construction with factory painted finish
- Twin motor starter for manual on/off operation
- Replaceable screen decks

OPTIONAL FEATURES

- Circular inlets and outlets
- Right or left-hand outlets
- Above deck or side mounted drives
- Isolators with support base
- Overhead coil spring suspension mounting
- Dust-tight covers and sight ports
- Booted inlets and outlets for dust containment
- Tension wedges for quick change of screen decks
- Variable frequency controls to vary feed rates
- Ball tray decks to reduce screen 'plug' blinding

SPECIAL DESIGNS

For difficult to handle, fluffy, light-density materials or when large screen openings (i.e. larger than 1" square mesh openings) are being used, drives with lower frequency and higher amplitude can be substituted.

For these types of applications, 900 or 1200 RPM drives are available. Call for details.

The Cleveland Vibrator Company EMS electromechanical screener feeders are designed for precise screening where high efficiency is required in the final particle size.

Units are equipped with twin motor drives and are mounted horizontally, requiring no gravitational assistance. Typical EMS screener feeders are equipped with 1800 RPM vibrators, providing a 0.10° stroke. Force output of the drives can be varied to decrease stroke and reduce final conveying.

DISCHARGE OPTIONS

- Standard Flat Chute
- Circular Outlet
- Tapered Chute
- Side Discharge

ISOLATION OPTIONS

- Air Mounts
- Coil Springs
- Rubber-In Shear
- Marsh-Mellow® Mounts

EQUIPMENT OPTIONS

- Leveling Gate
- Dust Covers
- Liners
- Impact Plates

CONTROL OPTIONS

- Electro-Mechanical
Magnetic Starter • Variable Frequency • Dynamic Brake
- Air Powered
Filter Regulator Lubricator • Explosion-Proof Solenoid
- Electromagnetic
Variable Amplitude

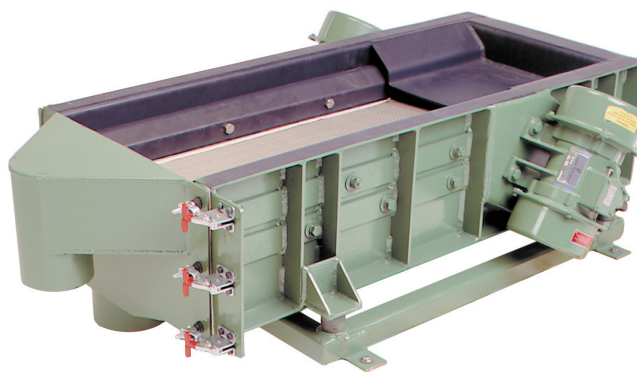

▲ Model EMBS with Ball Deck Tray

ELECTROMECHANICAL SCREENER FEEDERS

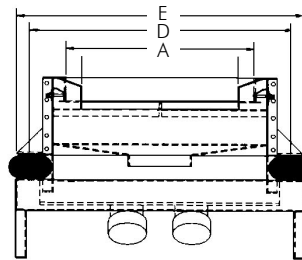
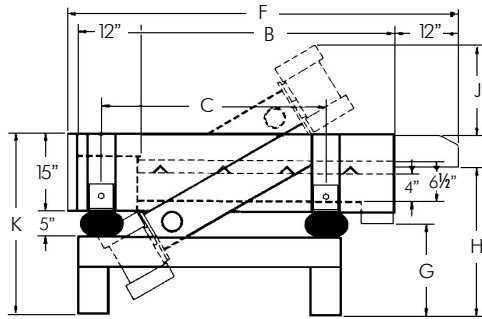

Model EMS with Grizzly Bar Sections

EMS • ELECTROMECHANICAL SCREENER FEEDERS

A	B	C	D	E	F	G	H	J	K	Model	Approx.
Effective	Effective	Support	Support	O.A.	O.A.	Fines	Overs	Above	O.A.	Vibratory	Shipping
Screen	Screen	Centers	Centers	Width	Length	Disch.	Disch.	Deck	Height	Drive	Weight
Width	Length	Length	Width			Height	Height	Height		(2 Each)	
12"	36"	41"	25"	29"	60"	20"	26"	18"	35"	9-6	617 lbs.
12"	48"	53"	25"	29"	72"	20"	26"	18"	35"	9-6	723 lbs.
12"	60"	65"	25"	29"	84"	20"	26"	18"	35"	9-6	829 lbs.
18"	36"	41"	30"	35"	60"	23"	29"	18"	38"	9-6	776 lbs.
18"	48"	53"	30"	35"	72"	23"	29"	18"	38"	9-6	1134 lbs.
18"	60"	65"	30"	35"	84"	23"	29"	18"	38"	9-6	1093 lbs.
18"	72"	77"	30"	35"	96"	23"	29"	18"	38"	9-6	1251 lbs.
18"	96"	101"	30"	35"	120"	23"	29"	19"	38"	13-6	1768 lbs.
18"	120"	125"	30"	35"	144"	23"	29"	19"	38"	13-6	2086 lbs.
24"	48"	53"	37"	42"	72"	23"	29"	19"	42"	13-6	1346 lbs.
24"	60"	65"	37"	42"	84"	23"	29"	19"	42"	13-6	1557 lbs.
24"	72"	77"	37"	42"	96"	23"	29"	19"	42"	13-6	1768 lbs.
24"	96"	101"	37"	42"	120"	23"	29"	21"	42"	18-6	2191 lbs.
24"	120"	125"	37"	42"	144"	23"	29"	23"	42"	24-6	2614 lbs.
30"	48"	53"	43"	48"	72"	29"	36"	19"	44"	13-6	1346 lbs.
30"	60"	65"	43"	48"	84"	29"	36"	21"	44"	18-6	1557 lbs.
30"	72"	77"	43"	48"	96"	29"	36"	23"	44"	24-6	1768 lbs.
30"	96"	101"	43"	48"	120"	29"	36"	23"	44"	24-6	2191 lbs.
30"	120"	125"	43"	48"	144"	29"	36"	23"	44"	24-6	2614 lbs.
36"	60"	65"	49"	54"	84"	29"	36"	21"	44"	18-6	2086 lbs.
36"	72"	77"	49"	54"	96"	29"	36"	21"	44"	18-6	2403 lbs.
36"	96"	101"	49"	54"	120"	29"	36"	23"	44"	24-6	3037 lbs.
36"	120"	125"	49"	54"	144"	29"	36"	23"	44"	24-6	3872 lbs.
48"	60"	65"	61"	66"	84"	29"	36"	23"	45"	24-6	2614 lbs.
48"	72"	77"	61"	66"	96"	29"	36"	23"	45"	24-6	3037 lbs.
48"	96"	101"	61"	66"	120"	29"	36"	26"	45"	34-6	4083 lbs.
48"	120"	125"	61"	66"	144"	29"	36"	26"	45"	34-6	4929 lbs.

* These dimensions should not be used for installation purposes. Certified prints are provided prior to shipment.



GRAVITY FLOW SINGLE DRIVE SCREENERS

The Cleveland Vibrator Company gravity flow design is downsloped 20° for gravity assisted material conveyance. These screeners use a single rotary electric vibrator drive.

All dimensions are based on an installation angle of 20°. Call our factory for more detailed information at:

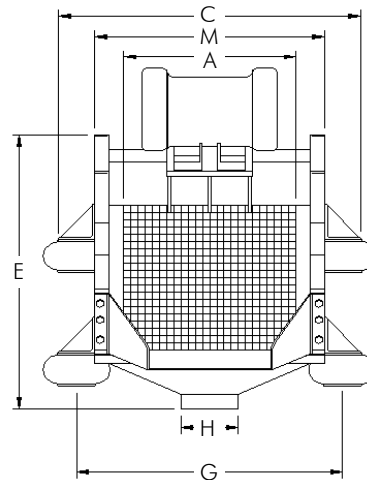
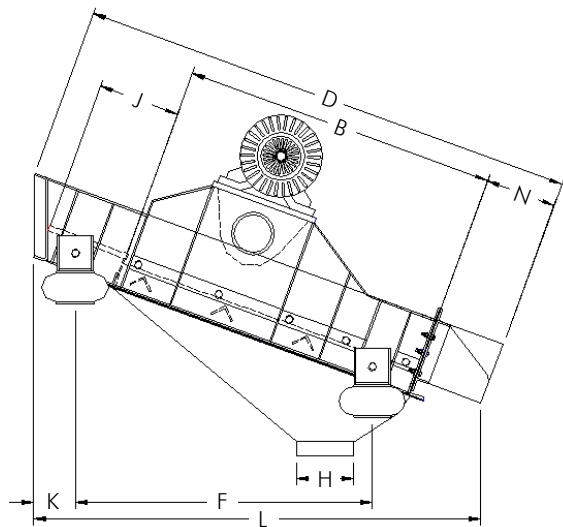

SC-E • GRAVITY FLOW SINGLE DRIVE SCREENERS

MODEL NUMBER	EFFECTIVE SCREEN AREA	A	B	C	D	E	F	G	H	J	K	L	M	N
SC-E - 1236	3 sq. ft.	12"	36"	31 ¼"	51 ½"	23 ¼"	22 ½"	27 ¼"	6"	8"	10"	46 ¾"	19 ¼"	6"
SC-E - 1848	4 ½ sq. ft.	18"	48"	37 ¼"	63 ½"	29"	30"	33 ¼"	6"	8"	10"	57 ⅞"	25 ¼"	6"
SC-E - 2448	8 sq. ft.	24"	48"	43 ¼"	63 ½"	29"	30"	39 ¼"	6"	8"	10"	57 ⅞"	31 ¼"	6"
SC-E - 3660	15 sq. ft.	36"	60"	59 ¼"	77 ½"	37 ¼"	37 ½"	53 ¼"	8"	10"	12 ½"	70 ½"	43 ¼"	6"
SC-E - 4872	24 sq. ft.	48"	72"	71 ¼"	93 ½"	51"	45"	65 ¼"	12"	12"	15"	85"	55 ¼"	8"
SC-E - 4896	32 sq. ft.	48"	96"	71 ¼"	117 ½"	62"	52 ½"	65 ¼"	12"	12"	15"	107 ½"	55 ¼"	8"





LABORATORY SCREENERS

HK Technologies, Inc.

AN AFFILIATE OF

CLEVELAND VIBRATOR COMPANY

Our HK-8 and HK-12 line of laboratory sieving and screening units utilize high speed, rotary electric, high speed vibratory drives to generate a unique vibratory motion that will effectively handle any powder or liquid laboratory or small batch application. The HK-8 and HK-12 can run as a single deck unit or multiple deck systems.

For difficult to screen applications add the HK Ultrasonic Deblinding System to handle the most difficult screening applications. Wire mesh screening down to 25 micron (635 mesh) and finer micron sizes down to 5 micron are available with Precision E-Form type sieves.

The HK Ultrasonic Sieving Tower provides advanced Sieving technology utilizing electromagnetic vibration for multiple deck sieve analysis. The Sieving Tower can be coupled with ultrasonic Sieving technology for unmatched quality and precision sieve testing.

The Laboratory/Pilot Sieving Towers utilizes two horizontally mounted high-speed rotary electric vibratory drives which can handle 8 full size test sieve frames or up to 16 half frames.

Both the Ultrasonic Sieving Tower and Laboratory/Pilot Sieving Tower can accommodate sieves in 3, 8 and 12 inch sieve frames and can handle wet or dry applications.

- 100% utilization of screen surface
- Reduces throughput from hours to minutes
- Re-screenable screen frame
- Multiple screen decking
- Available in 8, 12, 17, 24, and 36" models
- Custom sizes available

SEE p.10 FOR SIZING CHART

HK-12 Model with 12" diameter screen, ultrasonic deblinding assembly & vibratory feeder



Lab Sieve ▲

Lab Sieve Tower ►



ULTRASONIC DEBLINDING SYSTEM

HK Technologies, Inc.

AN AFFILIATE OF

CLEVELAND
VIBRATOR COMPANY

The HK Ultrasonic Deblinding System eliminates the clogging or blinding of wire mesh when screening powder products such as ceramics, powder metals, pharmaceuticals and other powder products.

The HK Ultrasonic Deblinding System provides a proprietary ultrasonic vibration that is transmitted to the wire mesh allowing for finer particles to pass freely through the wire mesh.



▲ Ultrasonic Generator

ULTRASONIC ADVANTAGES

The benefits of applying The HK Ultrasonic System to your screening equipment include:

- Increased screening rates up to 10 times
- Eliminate screen blinding or clogging
- Greatly increase production yields
- Finer mesh screening down to 20 Microns (635 Mesh)
- Multiple deck screening with one ultrasonic generator
- 100% utilization the screen surface

CONVERSION SYSTEMS



Our HK Ultrasonic Conversion Systems allows you to easily convert any gyratory screener to a high throughput ultrasonic screener, no matter who manufactured it!

Simply replace your existing screen frame with the HK Ultrasonic screen frame and you now have a highly efficient ultrasonic screening system capable of increasing your throughputs up to ten times!

HYBRUTE SCREENERS

HK Technologies, Inc.

AN AFFILIATE OF

CLEVELAND
VIBRATOR COMPANY

The Cleveland Vibrator Company's HyBrute™ screener is unique to the material handling industry. This hybrid unit combines the high volume capacity of a brute force screener with the fine screening capabilities of an ultrasonic screener.

HyBrute screeners process materials at faster rates and with efficiency previously unattainable in the industry.

These screeners are available in three sizes, with screen areas of 4½, 8, or 18 square feet.

The HyBrute series of screeners uses ultrasonic screen excitation to effectively screen materials through a very fine mesh. These units offer many benefits to manufacturers and material processors with increased capacity and screening efficiency.

SYSTEM BENEFITS

- Higher sieving efficiency
- Faster production rates
- Screening down to 20 microns
- Consistency with less blinding
- Increased volume



TWIN DRIVE GYRATORY SCREENERS

HK Technologies, Inc.

AN AFFILIATE OF CLEVELAND VIBRATOR COMPANY



▲ Twin Drive Gyrotory Screener

The Twin Drive Vibratory Screeners three-dimensional motion allows for greater throughput of difficult to screen products or high capacity throughputs. The distinctive vibratory action along with the vertical discharge of fines provides a screener that can handle the most difficult screening applications.

Couple the Twin Drive Screener with our Ultrasonic Deblinding System for unmatched product throughputs and the ability to screen at finer mesh with maximum product yields.

All models are easily disassembled for quick and easy clean up or screen changeover. The low profile, vertical fines discharge design allows for production screening in tight quarters where standard screeners just won't work.

Units are available in 24, 36, and 48 inch diameters.

HKC SERIES

The HKC Series powder check screeners offer affordable and efficient high capacity check screening where portability or limited space is important.

The HKC Series has been designed with a low profile and vertical discharge of fines, allowing for screening where space is limited. The Model HKC can easily be rolled over a box or fiber drum for check screening of your powdered materials.

All units are constructed of 10 gauge 316 stainless steel for quick and easy cleanup or screen changeover. Screen diameters are available in 12, 17, 24, 36 and 48 inch diameter models and can be powered by either a powerful rotary electric vibratory drive or air vibration. This unique vibratory action allows for easy removal of all oversize materials or debris from your product stream.



▲ HKC Portable Screener (Disassembled)

MESH • CONVERSION CHART



U.S. MESH	MICRONS	INCHES	MILLIMETERS
3	7086	.279	7.08
4	4750	.187	4.74
6	3360	.132	3.36
8	2464	.097	2.38
10	2000	.075	2.00
12	1680	.0661	1.68
14	1410	.0555	1.41
16	1190	.0469	1.19
18	1000	.0394	1.00
20	840	.0331	.84
25	710	.028	.71
30	590	.0232	.59
40	420	.0165	.42
50	297	.0117	.297
60	250	.0098	.25
70	210	.0083	.21
80	177	.007	.177
100	149	.0059	.149
120	125	.0049	.125
140	105	.0041	.105
170	88	.0035	.088
200	74	.0029	.074
250	62	.0024	.062
270	53	.0021	.053
325	44	.0017	.044
400	37	.0015	.037
450	32	.0013	.033
500	25	.0010	.025
635	20	.0008	.020
1250	10	.0004	.010
2500	5	.0002	.005

PRODUCT TESTING

Send us a sample of your material!

The Cleveland Vibrator Company maintains a testing lab where samples of customer materials can be received and tested to ensure satisfactory performance of our products.





Since 1923 Cleveland Vibrator Company has been designing, manufacturing and supplying vibratory products and offering services to meet material handling needs. Our diverse products and knowledge ranges from the precise challenges of fine powder screening to the most rugged feeder, screener and conveyor applications.

In addition to our breadth of capabilities, we differentiate ourselves with a unique focus on quality, integrity and customer service that has made us a partner with more than 15,000 organizations around the world since our opening over 85 years ago.

